

FORMA

DESIGN / AZ CREATIONS





Forma 77













TECHNICAL DATA

CHAIR WITH
SYNCHROTEK
MECHANISM

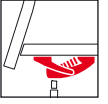

DIMENSIONS

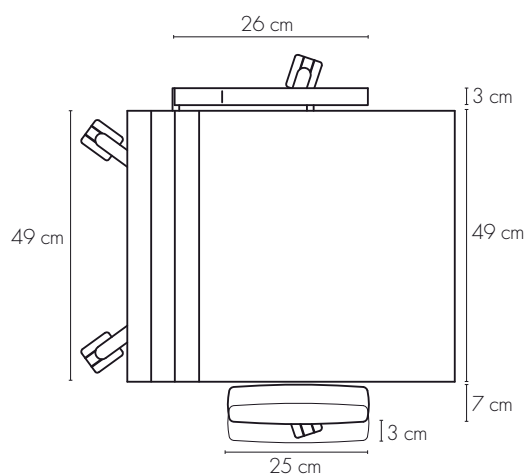
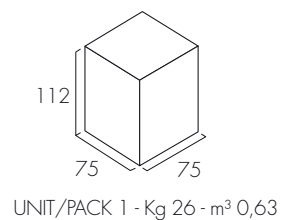
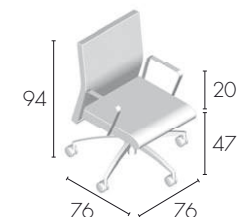
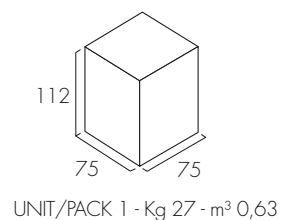
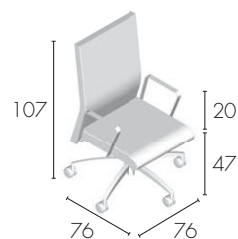
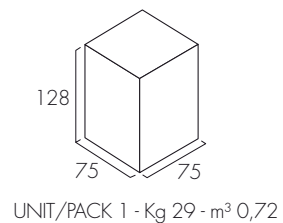
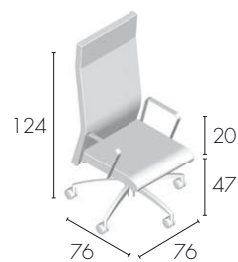
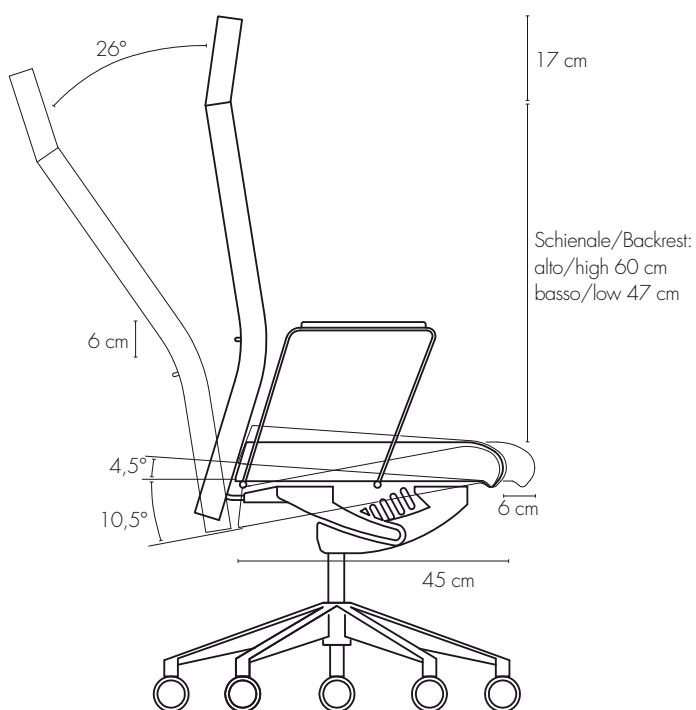

RECYCLABILITY

77,6%

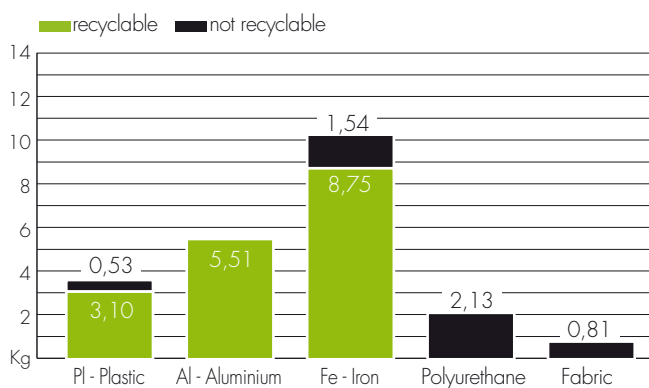

PROGETTO BENESSERE



- 1 Pressione sullo schienale di spalle e scapole.
Pressure of shoulders and blade-bones on the backrest.
- 2 Pressione su supporto lombare dell'area sacrale.
Pressure of the sacral area on the lumbar support.

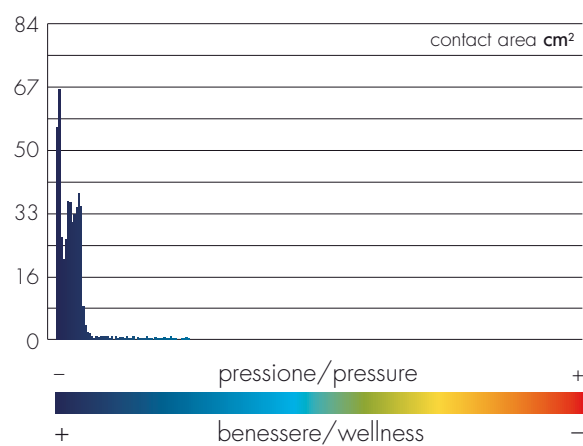

- 3 Pressione sul sedile di bacino e cosce.
Pressure of pelvis and thighs on the seat.

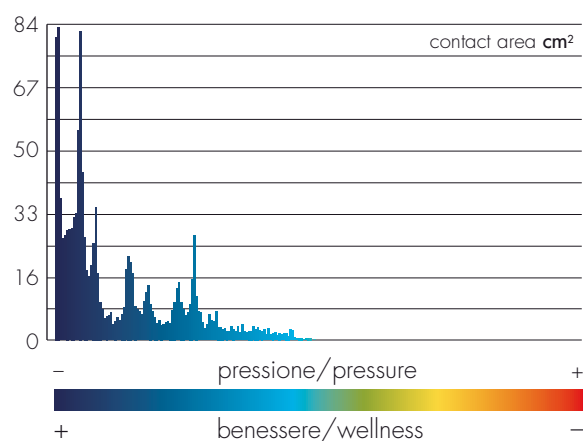

CERTIFICATIONS



Certification and guarantee of absolute product quality



IQNet Certified
Management System



ISO 9001:2000
Quality



ISO 14001:2004
Environmental



OHSAS 18001:2007
Safety

EN 1335

EN 13761

D.Lgs 81

EN 1728

EN 15373

PG
GOSSTANDART

UN EN 9175
CLASSE 1 IM

ESD
STM 12.1

5
YEAR WARRANTY